

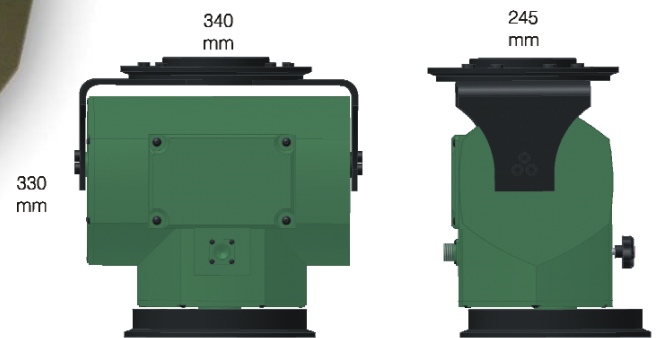

# Pan & Tilt Positioner



- Carrying Capacity of 30kg
- MIL STD 810E Approved
- Adjustable Internal Limits
- IP66 Weatherproof Standard Approval



*The Future Never Sounded So Good...*

## Features

- Carrying capacity of 30 kg
- IP66 weatherproof standard approval
- Precision ball bearings ensure the unit remains square on both axes
- Stainless steel shafts and fittings eliminate corrosion

- Internal limit adjustment
- Resilience to extreme weather conditions
- All metal gear transmission
- Low backlash for stability in high winds
- Ironless rotor motors

## Specification

<b>Construction:</b>	Aluminium Casting	<b>Overrun:</b>	Nil
<b>Weatherproof:</b>	To IP66 (equal to heavy seas)	<b>Pan Angle:</b>	360
<b>Sealing:</b>	Double edge lip seals on shafts and gaskets between lid and body	<b>Tilt Angle:</b>	+/- 15
<b>Gearing:</b>	All steel precision gear train with stainless steel shafts	<b>Limit Adjustment:</b>	Internal fingers accessible via hatch with full load in place.
<b>Motors:</b>	Ironless Motor	<b>Mounting Details:</b>	To suit requirement
<b>Pan Speeds:</b>	2 deg/sec or 3.5 deg/sec	<b>Weight:</b>	<24 Kg
<b>Tilt Speeds:</b>	1 deg/sec	<b>Power Consumption:</b>	<22W per axis
<b>Backlash:</b>	Better than 0.2 of a degree	<b>Operating Temperatures:</b>	-40 to +55 C +solar radiation
<b>Approvals:</b>	MIL STD 810E	<b>Connector:</b>	MIL 5015
		<b>Carrying Capacity:</b>	30 Kg (balanced load)

**South Midlands Communications Ltd**

SM House, School Close, Chandlers Ford Industrial. Est. Eastleigh, Hampshire, SO53 4BY ENGLAND  
Tel: +44 (0)23 8024 6200 Fax: +44 (0)23 8024 6206 Email: sales@smc-comms.com Web: www.smc-comms.com